

Subject to change without prior notice!

Document number: 65639 Rev.1.0

Eskilstuna 2015-12-16.DF

PP227-1000

BRUKSANVISNING • BRUGSANVISNING • KÄYTTÖOHJE • OPERATING INSTRUCTIONS

GEBRAUCHANWEISUNG • MODE D'EMPLOI • GEBRUIKSAANWIJZING

ISTRUZIONI PER L'USO • INSTRUCCIONES DE USO • INSTRUÇÕES DE USO

*Thank you for the faith you have shown in us by choosing a REHOBOT product. REHOBOT stands for products of high quality and it is our hope that you will be able to use this product for many years.*

To avoid functional disturbances, we recommend that you read these instructions thoroughly before using the product.

### Technical description (Fig. 1 + 2A,B,C)

Max. working pressure:	227.5 MPa (2275 bar, 33000 psi)
Required air pressure:	Fig. 2A
Capacity:	Fig. 2B
Air consumption:	Fig. 2C
Total oil capacity:	1,050 cm <sup>3</sup> (64 in <sup>3</sup> )
Effective oil capacity:	1,000 cm <sup>3</sup> (61 in <sup>3</sup> )
Weight inc. oil:	6.2 kg (13.7 lbs)

Because the pump has a rubber bladder fitted inside the tank it can be used either horizontally or vertically.

### Safety feature

The pump is equipped with a safety valve that regulates the output pressure. The safety valve is set to the maximum working pressure at the factory.

### Installation

#### Connecting compressed air

The pump requires a compressed air pressure of at least 0.65 MPa (6.5 bar, 94.3 psi) to develop hydraulic pressures of 227.5MPa (2275 bar, 33000 psi).

Make sure that the air pressure does not exceed 1.0 MPa (10 bar, 145 psi) as this could damage the pump. To ensure efficient operation and long life use clean compressed air with a water trap. Connect the compressed air line using a G 1/4" coupling, as shown in Fig. 1, item B.

#### Connecting the hydraulic hose

Connect the hydraulic hose using a G 1/4" coupling (Fig. 1, item H) or use REHOBOT quick couplings. When connecting a hydraulic hose or coupling to the pump it is important to use a spanner to hold the connector on the pump and prevent it from turning (Fig. 3).

#### Bleeding the hydraulic system

When hoses or tools are connected to the pump they can introduce air into the hydraulic system, which could lead to operating problems. Bleed the system by running the tool or cylinder through 3–4 cycles (by pumping out until fully extended, then releasing) with no load. Make sure that the tool or cylinder is kept lower than the pump to allow the air to flow back into the oil reservoir of the pump. Then hold the pump with the oil reservoir at the top while pressing the pump pedal and release pedal at the same time (Fig. 4) for around 15 seconds. It may be necessary to top up the oil depending on the volume of air in the connected hoses or tool, see Filling with oil.

### Accessories

The pump can be equipped with accessories such as a gauge / gauge adapter, etc. It is possible to connect a return pipe. All rams, accessories, and tools that are connected to the pump must be designed for a working pressure that is equal to or higher than the maximum working pressure of the pump. NOTE! The pump is equipped with a safety valve on the hydraulic side. It has been factory-set for maximum working pressure. The safety valve can be adjusted ONLY by REHOBOT or a workshop authorized by REHOBOT. For simple reduction of the hydraulic pressure, we recommend you to use a reduction valve for incoming compressed air.

### Use

#### Starting

To extend the cylinder or tool, press the pump pedal (Fig. 5, item A). The pump will stop and maintain the achieved hydraulic pressure when the pedal is released in the neutral position.

#### Releasing

To release the cylinder or tool, press the release pedal (Fig. 5, item B). Hold the pedal down until the cylinder has moved back to the desired position.

NOTE! If the pump is overfilled when a cylinder or tool is released, the surplus oil will run out of the valve in the filler plug.

### Maintenance

When necessary lubricate moving parts such as the pneumatic piston and valve with high-grade grease.

### Service

#### Filling with oil

Check the oil level before use. Always measure the oil level with the cylinder or tool in the lowest or retracted position. To ensure efficient operation use an hydraulic oil that conforms to ISO VG 10.

- Stand the pump up with the pneumatic motor lowermost (Fig. 6).
- Unscrew the oil filler plug (Fig. 6, item A).
- Fill the oil reservoir through the filler hole until the oil reservoir is completely full (1,050 cm<sup>3</sup>, 64 in<sup>3</sup>).
- Screw the oil filler plug back into place.

For safety reasons, service and repair of this product must be done by a knowledgeable person. Upon the slightest doubt, contact your distributor for information about the nearest authorized workshop.

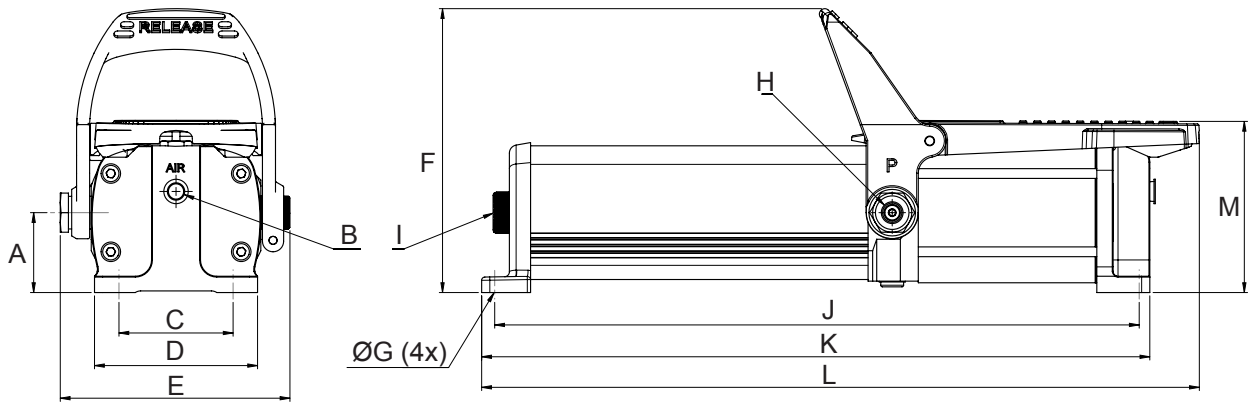

	A	B	C	D	E	F	G	H*	I	J	K	L	M
mm	49	G1/4"	70	100	140	174	7	G1/4"	G3/8"	395	410	440	105
in	1.9	G1/4"	2.8	3.9	5.5	6.9	0.3	G1/4"	G3/8"	15.6	16.1	17.3	4.1

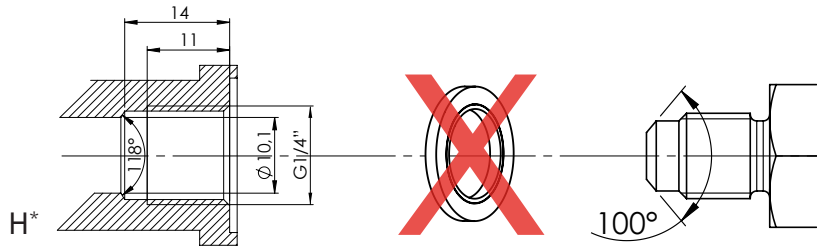

Fig. 1

Erforderligt lufttryck/ Nødvendig lufttrykk/ Påkrævet lufttryk/ Tarvittava ilmanpaine/  
 Required air pressure/Erforderlicher Luftdruck/ Pression d'air nécessaire/Benodigde luchtdruk/  
 Pressione dell'aria necessaria/ Presión de aire exigida/ Pressão de ar necessária

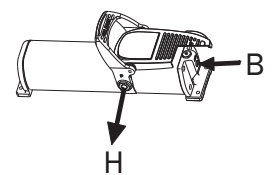
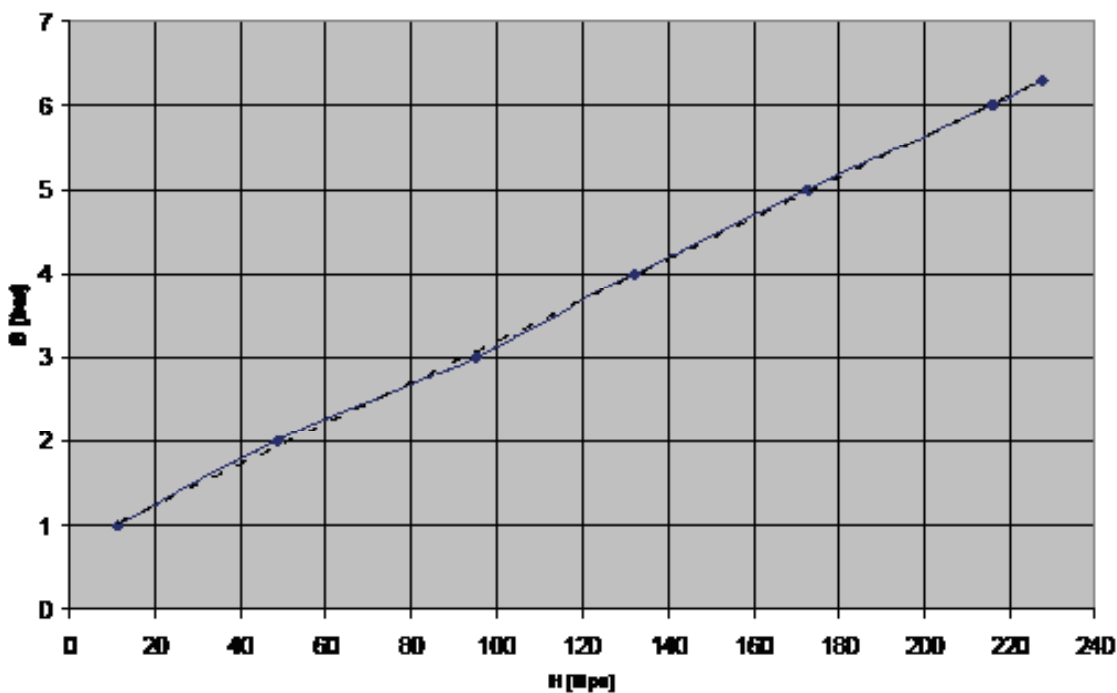

Fig. 2A

Kapacitet/Kapasitet/Kapacitet/Tuotto/Capacity/Kapazität/Capacité/ Capaciteit/Portata/Capacidad/Capacidade

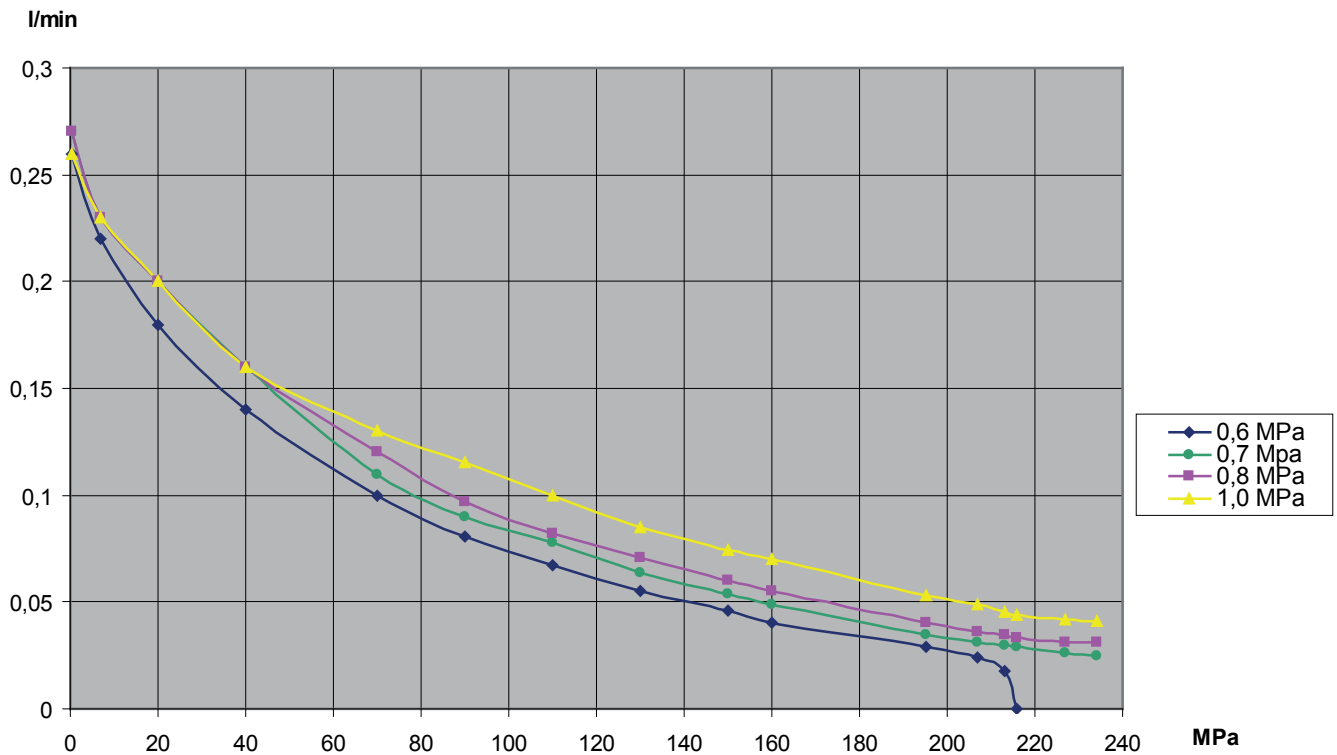

Fig. 2B

Luffförbrukning/Luftforbruk/Luftforbrug/Ilmankulutus/Air consumption/Luftverbrauch/Consommation d'air/Luchtverbruik/Consumo d'aria/Consumo de aire/Consumo de ar

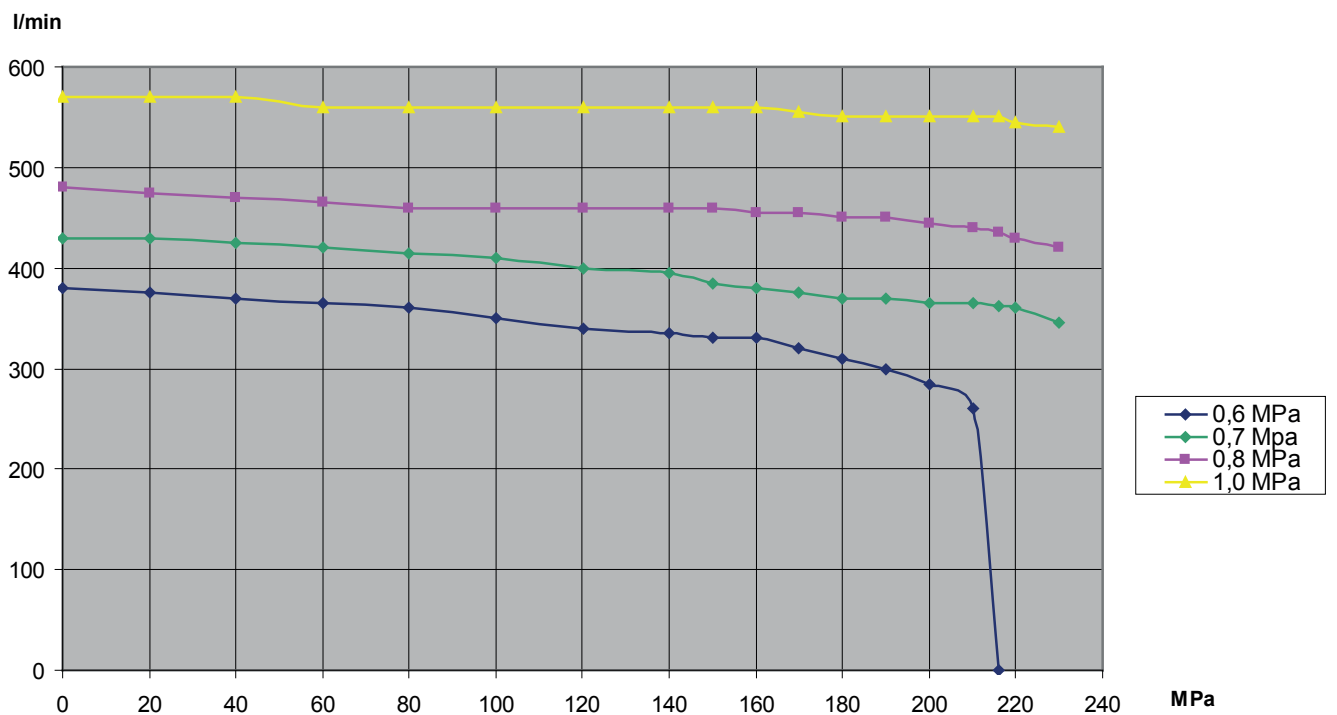
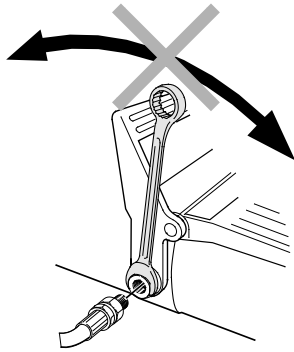
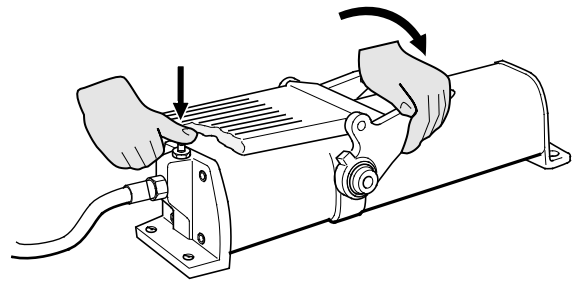

Fig. 2C



**Fig. 3**



**Fig. 4**

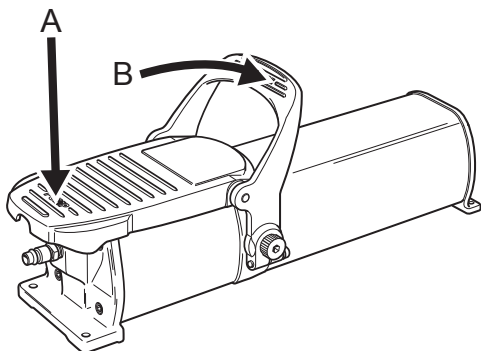

**Fig. 5**

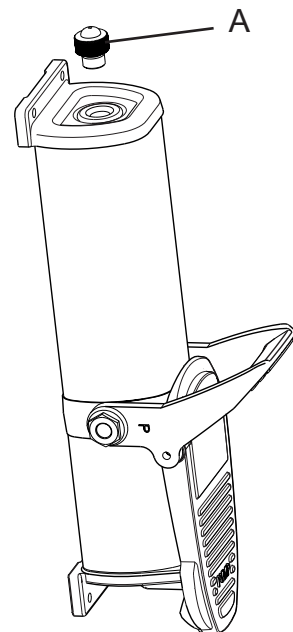

**Fig. 6**